

BUILDING TYPE 'A'	4,140 SQ. FT. X 3 = 12,420 SQ. FT.
BUILDING TYPE 'B'	5,389 SQ. FT. X 1 = 5,389 SQ. FT.
BUILDING TYPE 'C/IV'	6,623 SQ. FT. X 2 = 13,242 SQ. FT.
BUILDING TYPE 'C/III'	6,545 SQ. FT. X 2 = 13,090 SQ. FT.
BUILDING TYPE 'D'	6,393 SQ. FT. X 2 = 12,786 SQ. FT.
BUILDING TYPE 'E'	8,500 SQ. FT. X 1 = 8,500 SQ. FT.
11 BUILDINGS TOTAL SQ. FT. =	65,427 SQ. FT.
65,427 SQ. FT. ÷ 150 SQ. FT. PER SPACE =	436 PARKING SPACES
PARKING PROVIDED	= 427 PARKING SPACES
INCLUDING 26 HANDICAP SPACES	

REVISIONS	BY

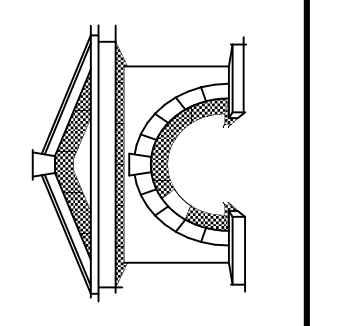

DAVE MANCINO
ARCHITECT
2450 Old Montrie Road
St. Augustine, Florida
PHONE/FAX: (904) 797-5553

David A. Mancino
AR 0010455

NEW MEDICAL OFFICES FOR:
DiMare Construction Company
3475 U.S. 1 SOUTH
ST. JOHNS COUNTY, FLORIDA

Date: FEB. 17, 2010
Scale: 1" = 30'
Drawn: DAM
Job No.:
Checked By: DAM
Sheet:
ST-1
Of: Sheets